

Machine vises

Accessories

●=Standard ●=Option

Model		Clamping bolt, nut, washer	Clamping block	Guide block (tempered steel)	Set plate (for installing 2 vises together)
Mechanical Force-multiplier Machine Vises	Vi Vi-1216	● 4 sets	● 4 pcs.	● 14	●
	Others	● 4 sets	● 4 pcs.	● 18	●
Mechanical Force-multiplier Machine Vises	Vis	● 4 sets	● 4 pcs.	● 14	●
Fine Machine Vises	VF	● 2 sets		● 18	
Hydraulic Machine Vises	VH VH-125	● 3 sets		● 16	
	VH-150~200			● 18	
Precision Machine Vises	VR VR-150	● 2 sets		● 16	
	VR-200			● 20	
Machine Vises	VG VG-100	● 2 sets		● 14	
	VG-125	● 2 sets		● 14	
	VG-150·175	● 2 sets		● 16	
	VG-200	● 2 sets		● 20	
Fixture Machine Vises, Precision type	VJ	● 2 sets	● 2 pcs.	● 18	
Large-size Machine Vises	VB VB-300	● 7 sets	● 4 pcs.	● 20	
	VB-400	● 7 sets	● 4 pcs.	● 22	
Super Precision Machine Vises	VP VP-80·100	● 4 sets	● 4 pcs.	● 14	
	VP-125	● 4 sets		● 18	
	VP-125F	● 4 sets			
Dual Clamping Machine Vises	KV	● 2 sets		● 16	

Guide Blocks (Tempered Steel)

■ Preparation in short time, and easy to achieve accuracy.

■ Strong against vibration and impact, and applicable to heavy-duty machining.

● Unstandard (unstraight) guide block is optional.

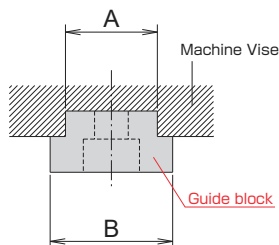

Guide blocks which TSUDAKOMA can supply

A	B (T-slot dimensions of tables for machining centers, milling machines)				
14	12	14	16	18	
16	12	14	16	18	20
18		14	16	18	20 22
20		14	16	18	20 22

[When order]

Please inform us of model name and then the size of A-B (16-18).

And the size of clamp kit is also altered, so inform us together.

● Red figures are supplied as standard.

	Straight handle	L-shape handle	Two-slot handle for hydraulic vise	Handle for force-multiplier vise	Special jaw	Work stopper
	● (Ratchet)			●	● Soft jaw	●
	● (Ratchet)			●		●
	● (Universal)					●
			●	●		●
	●	●				●
	●					●
	●	●				●
	●	●				●
	● (Universal)				● Block jaw	●
	● (Ratchet)			●		●
		●				●
		●				●
		●				●
		●			● V-type ● Vertical V-type ● Flat type	

Work Stopper Dimensions

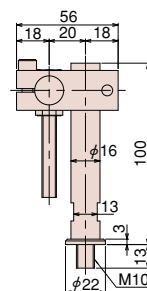
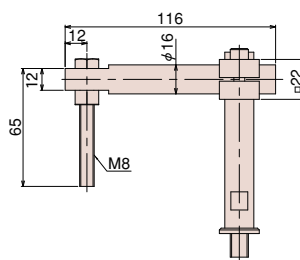
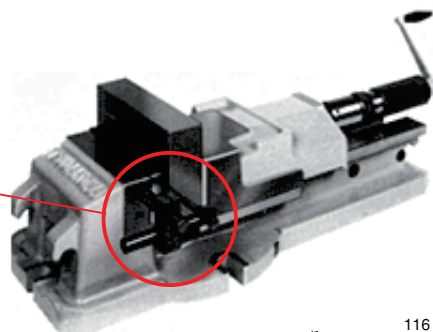
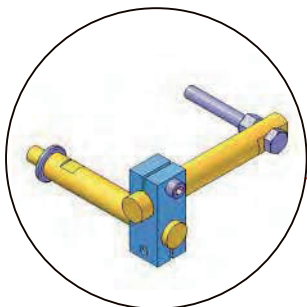

Model

Vi Vis VF VH VR VB-400 VG VJ VP

※Not available for VG-100