

For large-sized NC rotary tables

## TPC5 SR6 / SR12 / SR30

Single axis NC controllers automatically start large-sized TSUDAKOMA NC rotary tables by receiving M-signals from machining center.

Easy programming by simple input of the interactive system.

In increments of 0.001° (standard), 0.0001° or 1 sec.

Ready to set optional functions easily.

- With an optional function of B signal, the workpiece number, block number and tilting angle command can be entered from machining center.

- Operation can be programmed by machining center.

With "remote mode + M" specification

(Parameter change) **P.54**

※Corresponding to Cable option

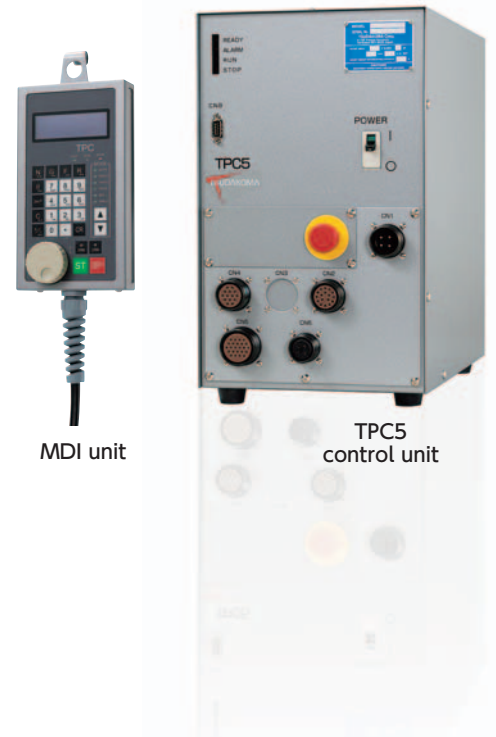

MDI unit

TPC5 control unit

### Applicable models

	SR6	SR12	SR30
RWB-250	●		
RWB-320,400,500		●	
RWM-160	●		
RWM-200 / 250 / 320-2	●		
RCH/RCV-800		●	
RCH/RCV-1000,1250			●
RCH/RCV-1600			●
TN-450			●
TWB-320	● (R)	● (T)	
TWB-630		●	
TWM-250*	● (R)	● (T)	
RBS/RBH-160	●		
RBS/RBH-250	●		
RBS/RBH-320		●	
RBM-160*	●		
TBS-250	●		

\* Table maximum rotation speed is limited.

RBH requires special TPC5.

### Cables

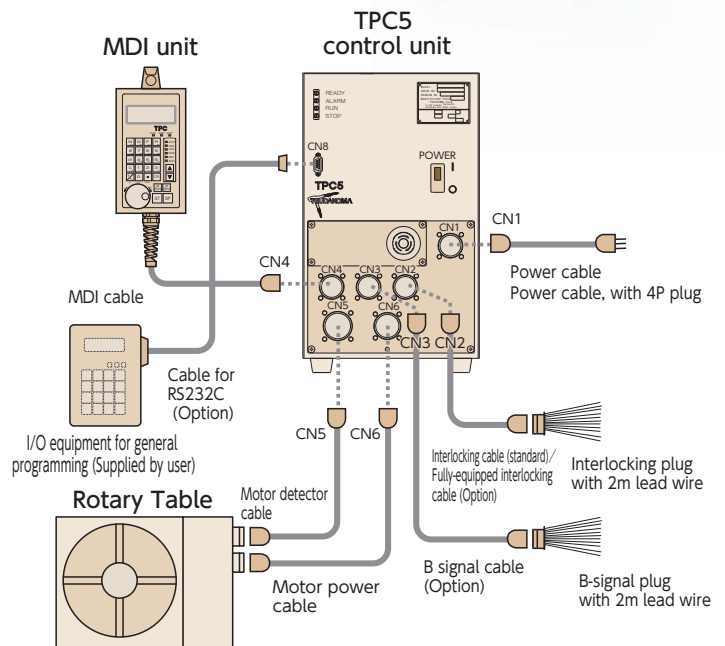

RS232C cable, fully-equipped interlocking cable, and B signal cable are optional items.

### Dimensions

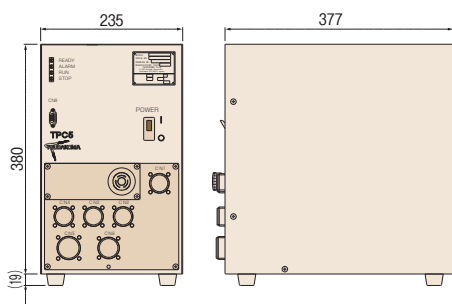

# TPC5 FUNCTIONS

## Operation panel

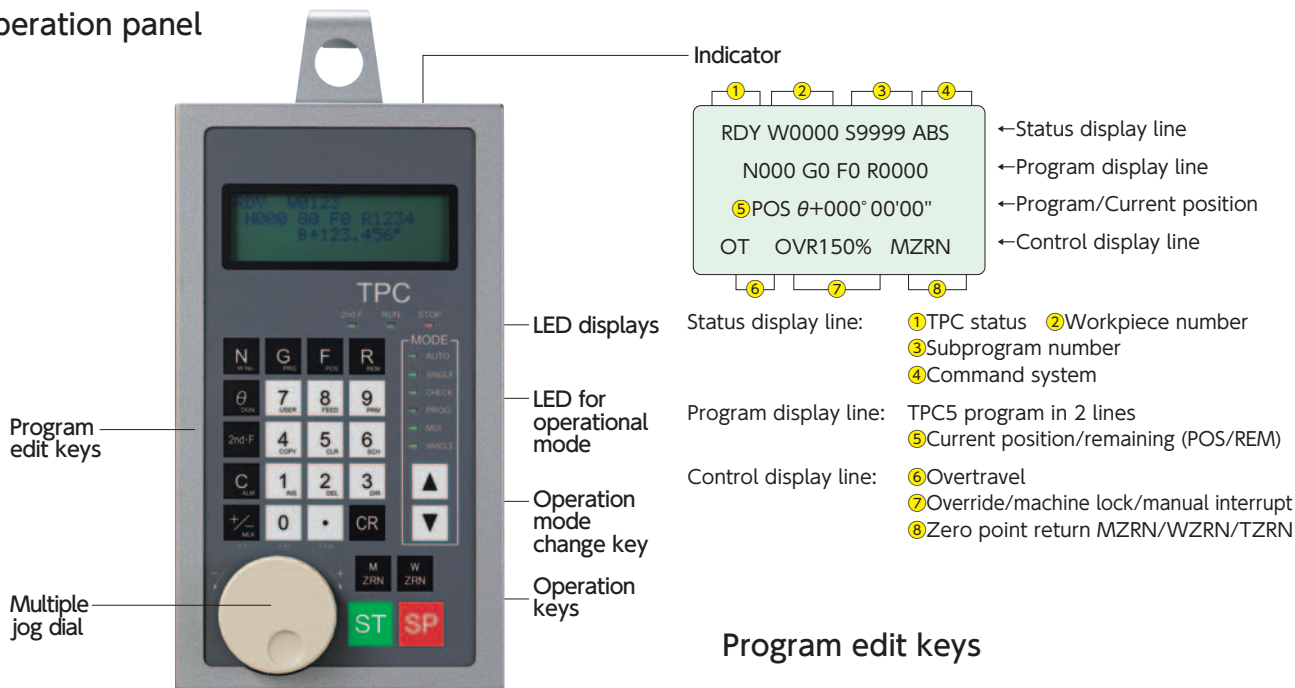

## OPERATION MODE

- AUTO** AUTO : Automatic operation interlocked with machining center.
- SINGLE** SINGLE : Single operation of TPC5.
- CHECK** CHECK : Program check and self-diagnosis.
- PROG** Program mode : Program entry.
- MDI** MDI mode : Setup operation.
- HANDLE** Handle mode : Manual pulse operation/jog mode.

## Program edit keys

- 2nd-F** + **N** Workpiece No. (Program No.)  
0000 to 9999  
100 programs registerable
- N** Block No. 000 to 999
- G** Operation command  
G0 to G4 : Movement command  
G5 to G9 : Assistance function
- F** Feed rate select command  
F0 : Rapid positioning speed  
F1 to F9 : Cutting feed rate
- R** Assistance code for codes
- θ** Travel distance command (angle, divided number)

G-code		R-code		θ-code	
No.	Command	No.	Command	Command	Setting
G0	Direct angle command	0001 to 9999	Number of Repetition (INC command)	Command angle	±000.001° to 999.999°
		0000	(ABS command)	Command angle	±000.000° to 360.000°
G1	Direct indexing number command	0001 to 9999	Number of repetitions	Number of divisions for 360°	±1 to 999999div.
G2	Arc-indexing number command	0001 to 9999	Number of divisions, Number of repetitions	Arc-angle indexed	±000.001° to 360.000°
G3	Lead cutting command	0000 to 0100	Number of table rotations	Command angle	±0° to 360.000°
G4	Zero point return command	0000	1st zero point return (mechanical zero point)	Not required	
		0001	2nd zero point return		
		0002	3rd zero point return		
G5	Sub-program call command	0000 to 9999	Number of repetitions	Sub-program No.	0000(0001) to 9999
G6	Subprogram return command		Not required	Not required	
G7	Program end command		Not required	Target address	000 to 999
G8	Workpiece coordinate system setting command		Not required	Reference coordinate	±0° to 360.000°
G9	Declaration command	0000	No operation	Not required	
		0001/0002	Clamp OFF/ON		
		0003/0004	Dowel OFF/ON	Dwell time	001 to 999 (×10msec)
		0005/0006	Indexing group control OFF/ON	Not required	
		0007/0008	Directional positioning OFF/ON		
		0009/0010	Completion signal control command OFF/ON	Completion signal selection	
		0011	Program display selection command	Not required	
		0012	Current position display selection command		
		0013	Remaining angle display selection command		

- RBS
- RBH
- RBM
- TBS
- RWE/RWA
- RN
- RWH
- RWA-B
- RWB
- RWB-K
- RCB
- RCH
- RCV
- Multi-Spindle RWM
- TWA/TN
- TWS
- TWB
- Multi-Spindle TWM
- RDS
- TDS
- TDB
- NC Controllers

- Accessories
- Options
- Technical Information

## TPC Machining Program Examples by TPC Controller

### Direct angle command : G0

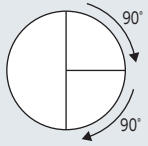

```

N000 G0 F0 R002 θ90.000 CR
      Quick Number of Repetition Indexing angle/time
N001 G7 θ000 CR
      End of program
    
```

Positioning at 90° twice

Return to N000 at the program end

### Direct indexing number command(even indexing) : G1

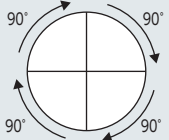

```

N000 G1 F0 R004 θ00004d CR
      360° is divided into quarters
N001 G7 θ000 CR
    
```

Dividing 360° by 4, four times

Return to N000 at the program end

### Arc-indexing number command(even indexing by an arbitrarily-set angle) : G2

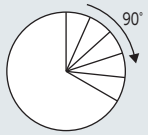

```

N000 G2 F0 R005 θ120.000 CR
      Indexing number Angle for indexing
N001 G7 θ000 CR
    
```

Dividing 120° by 5, five times

Return to N000 at the program end

### Uneven indexing

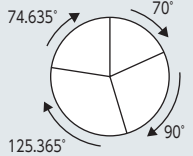

```

N000 G0 F0 R001 θ70.000 CR
N001 G0 F0 R001 θ90.000 CR
N002 G0 F0 R001 θ125.365 CR
N003 G0 F0 R001 θ74.635 CR
N004 G7 θ000 CR
    
```

Positioning at 70° once

Positioning at 90° once

Positioning at 125.365° once

Positioning at 74.635° once

Return to N000 at the program end

### (-) direction indexing

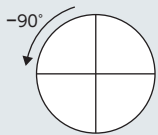

```

N000 G0 F0 R001 θ-90.000 CR
      Reverse
N001 G7 θ000 CR
    
```

Positioning at -90° once

Return to N000 at the program end

### Zero point return command : G4

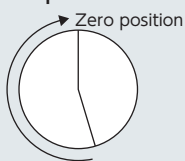

```

N000 G4 R000 CR
      Zero return To 1st zero position
    
```

Return to 1st zero position

## Remote mode + M specification(Parameter change) ※Corresponding to cable option

The rotary table is controlled by TPC with M-signal sent from a machining center through RS232C.

Note: This function may not be available for some machining centers. For details, ask the M/C manufacturer.

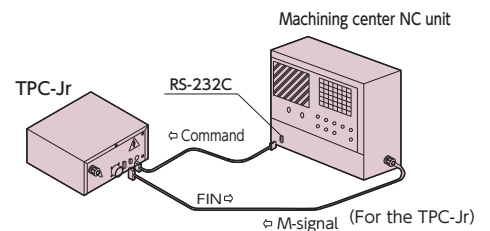

### Machining center :

**Program using Custom Macro** Necessary equipment TPC-Jr : Software for remote mode RS232C/interlock cable, RS232C cross cable  
 NC unit for a machining tool : RS232C connector and Custom Macro B (optional) (for FANUC).  
 For details, ask the machine manufacturer.

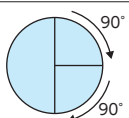

```

POPEN ;
DPRNT[/MOVA90.] ;
M70 ;
GO1Z100.F200 ;
DPRNT[/MOVA180.] ;
M70 ;
GO1Z100.F200 ;
PCLOS ;
    
```

RS232C port opens  
 Command of absolute positioning at 90° is transmitted to TPC  
 Positioning starts  
 Machining center in operation  
 Command of absolute positioning at 180° is transmitted to TPC  
 Positioning starts  
 Machining center in operation  
 RS232C port closes

# Installation of TPC controller

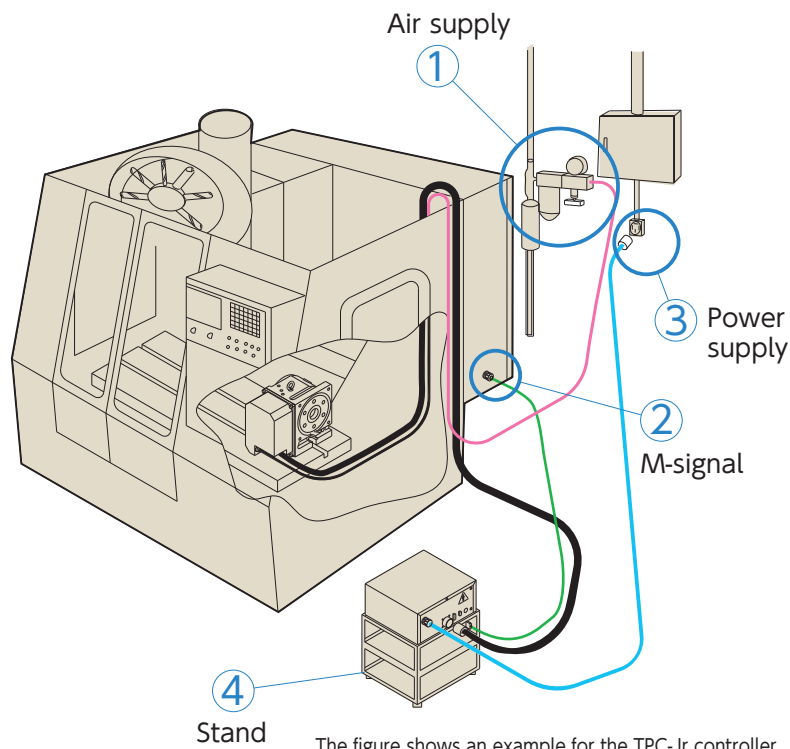

The figure shows an example for the TPC-Jr controller.

- RBS
- RBH
- RBM
- TBS
- RWE/RWA  
RN
- RWH
- RWA-B
- RWB
- RWB-K
- RCB
- RCH
- RCV
- Multi-Spindle  
RWM

- TWA/TN
- TWS
- TWB

- Multi-Spindle  
TWM

- RDS

- TDS  
TDB

- NC  
Controllers

- Accessories

- Options

- Technical  
Information

## To be provided by customers

### ① Air supply

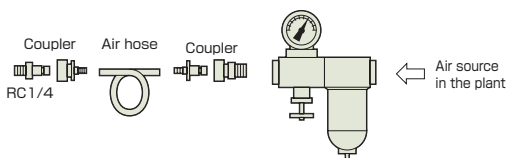

Air supply is necessary the pneumatic or air-hydraulic clamp system of the NC rotary tables with the TPC5 or TPC-Jr controller.

- The following are to be provided by customers:
- Air filter and regulator (Air pressure:0.49 MPa)
  - Air hose or air tube
  - Joint coupler (RC 1/4 for the table)

Some models need a 6 mm diameter tube for connection.

### ② M-signal

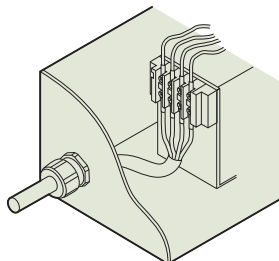

When the machining center controls the rotary table, it uses M-signals. Be sure to confirm with the machine manufacturer that M-signals or M-signal completion signals are transferred to the terminal block of the machine controller. If not, ask the manufacturer to do the required work.

☞ For the connection with an interlocking cable, refer to the examples shown on **P.56**

### ③ Power supply

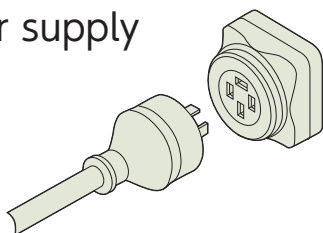

A socket for the TPC controller is necessary. A 3P plug is equipped with the TPC controller, and is recommended. The outlet for the connection is required.

- TPC side connector WF4420(Panasonic)
- Outer power supply connector WF1420 or the others(Panasonic)
- In case of the different type of connector, shall be arranged by the customer.

☞ For the power capacity of each controller, refer to **P.52**  
Conduct grounding (less than 100 ohm earth resistance)

### ④ Stand

A stand for the TPC controller is to be provided by the customer.

☞ For the dimensions and weight of the controller, refer to **P.48 to 50** **P.52**

TPC Controllers to Interlock with Machining Tools

- RBS
- RBH
- RBM
- TBS
- RWE/RWA  
RN
- RWH
- RWA-B
- RWB
- RWB-K
- RCB
- RCH
- RCV
- Multi-Spindle  
RWM
- TWA/TN
- TWS
- TWB
- Multi-Spindle  
TWM
- RDS
- TDS  
TDB

**TPC-Jr**

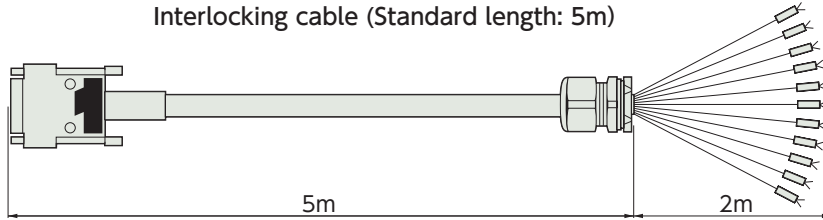

Connector dimension (on machining center)

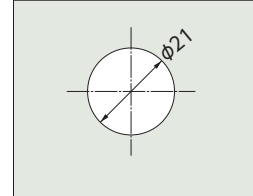

a) When a start signal and an indexing completion signal are used:

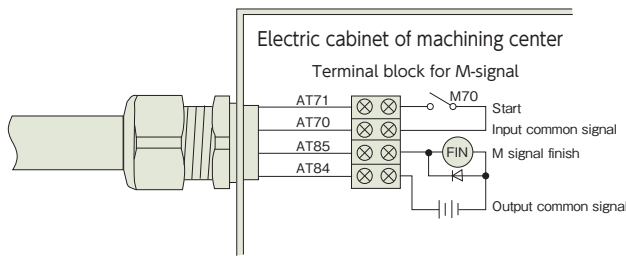

b) When all the signals through interlocking cables are used:

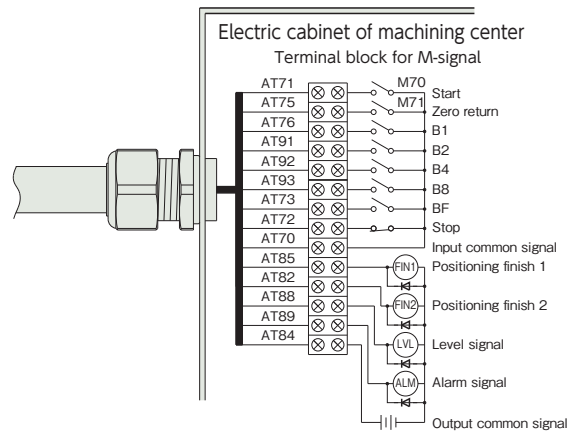

Note 1: When completion signals are received by a relay, the power supply should be 24VDC. Do not apply 100VAC or 200VAC.

Note 2: By changing the switch in the controller, a start signal is also available with the external power supply of 24VDC.

Note 3: Be sure to take countermeasures against electric noise by attaching surge protectors to relays for a machining center.

**TPC5**

Interlocking cable (Standard length: 5m)

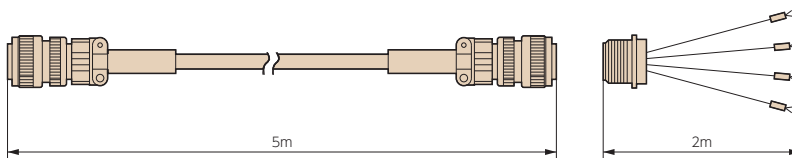

a) Standard interlock cable For interlocking only with M-signal and the completion signal

Connector dimension (To machining center)

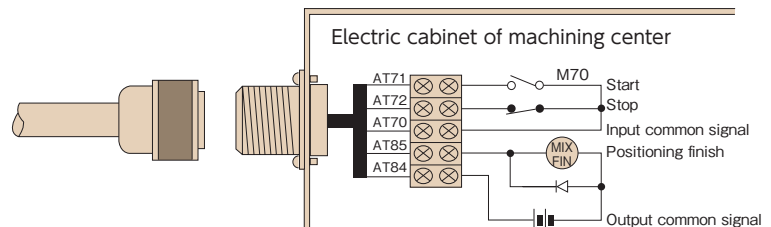
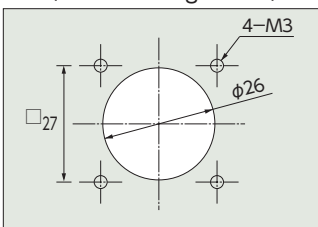

## TPC Controllers to Interlock with Machining Tools

### b) Fully-equipped interlocking cable (Option)

A variety of signals such as a stop or interlock input signal and a level or alarm output signal are available with this cable.

B signal cable is required when the setting functions for the workpiece number and angle data are used, or when the fixed indexing angle input system by an M-signal is used.

If you want to see some examples of the connections with this cable, please contact us.

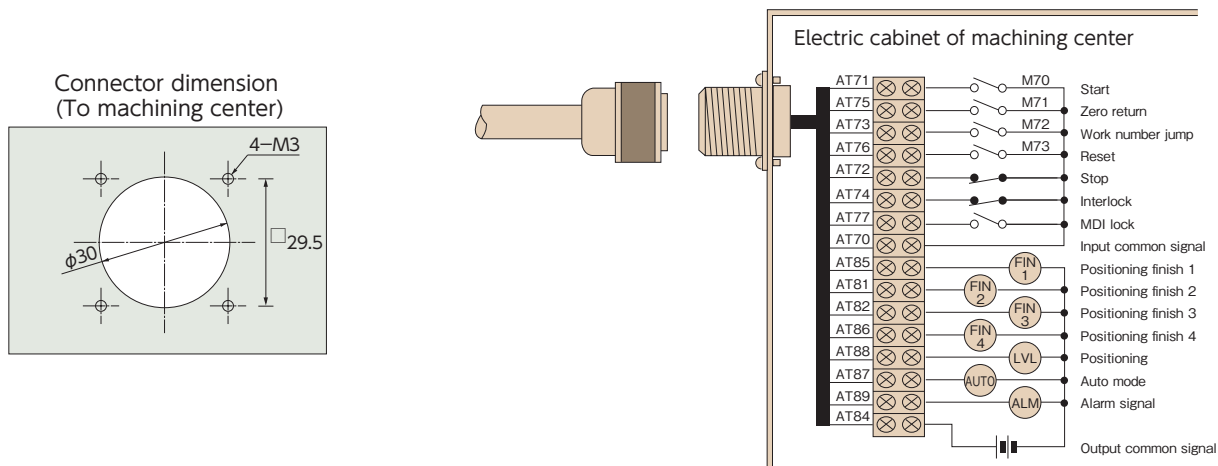

Note 1: When completion signals are received by a relay, the power supply should be 24VDC. Do not apply 100VAC or 200VAC.

Note 2: By changing the switch in the controller, a start signal is also available with the external power supply of 24VDC.

Note 3: Be sure to take countermeasures against electric noise by attaching surge protectors to relays for a machining center.

## Time Chart

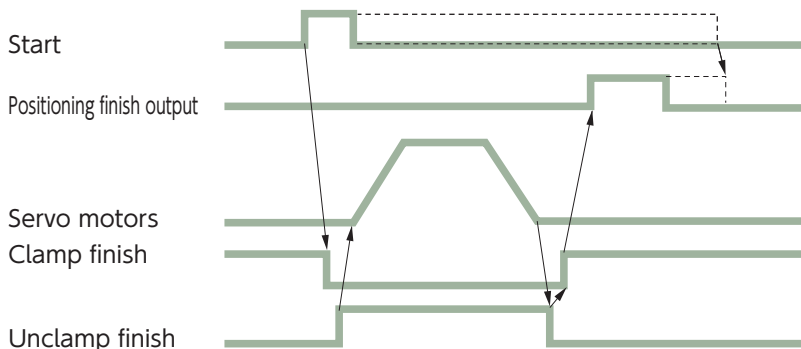

Note 1: A start input signal, in the form of either a pulse signal (of more than 10 msec) or level signal, can be accepted.

Note 2: During the interlocking operation with a machining center carried out through an M-signal, the M-signal should be completed by the positioning completion signal.

## TPC Standard Cable Specifications

The tables below shows the maximum outer diameter and the curved radius of standard cables which are supplied with the rotary tables ready for the TPC5 or TPC-Jr controller.

Unit: mm

	Cable	Order Code	Max. outer diameter	Min. curved radius
TPC5	Motor power cable	NS#20 (SANKEI MANUFACTURING CO.,LTD.)	20	90
	Motor signal cable			
TPC-Jr	Motor cable	NS#25 (SANKEI MANUFACTURING CO.,LTD.)	25	100

Model number, maximum outer diameter and curved radius may differ depending on specifications.

RBS

RBH

RBM

TBS

RWE/RWA  
RN

RWH

RWA-B

RWB

RWB-K

RCB

RCH

RCV

Multi-Spindle  
RWM

TWA/TN

TWS

TWB

Multi-Spindle  
TWM

RDS

TDS  
TDB

NC  
Controllers

Accessories

Options

Technical  
Information